

# LUBRICATION PUMP MPS 10 Type

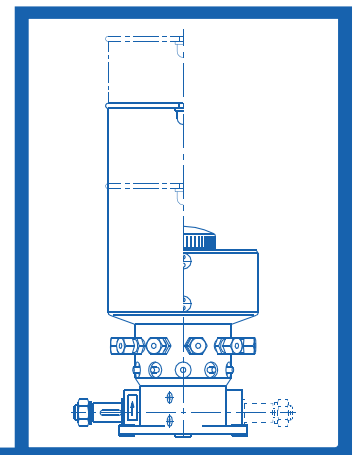

Lubrication pump MPS 10

Lubrication pump MPS 10



## Application

The pump is designed for oil or plastic grease lubrication of machines and devices which require continuous feeding of small amounts of lubricant. Lubricant is fed to each reception point through a separate line directly from the pump.

It is particularly recommended for lubricating machines for plastic metalworking, plastic and rubber forming, for lubricating construction, hoist and transport devices, industrial pumps, compressors, pulp and paper making machines, machines in inland navigation ships, agricultural machines etc.

## Construction

The pump consists of the following elements: a tank with a feeding device, forcing unit and drive unit. The forcing unit solution includes a suction-forcing section (comprising a piston and a pusher both located in a central shaft), forces lubricant successively to all outlets. There are control mandrels and radiating outlet couplings.

Balls driving the piston are built in the cylindrical body; their number corresponds to the number of outlets. Depending on the solution, the pump driving unit is adjusted to coupling the rotating, oscillating or reciprocating element of the machine on which the pump is installed or the pump has its own independent electrical motor drive.

## Operation

Drive unit elements make the pump central shaft rotate. During this movement, the pusher located in the shaft hits the front of the control mandrel and shifts together with the piston which makes lubricant be sucked to the stroke chamber. In the next phases of the shaft turn, the piston contacts the ball built in the body, returns and forces the lubricant out of the outlet stroke chamber. The process of lubricant forcing described above repeats analogically in the case of other outlets.

Delivery regulation may be performed for each outlet individually by turning control mandrels which restricts the piston stroke.

In the pump plastic grease tank there is a feeding device which separates the grease from the tank wall and forces it, with the use of feeding screw, through the filter to suction holes in the forcing unit.

## Technical details

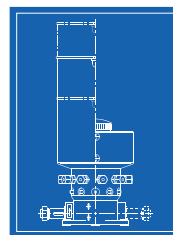

Number of outlets  
 Nominal pressure  
 Stroke delivery from one outlet  
 Time delivery from one outlet  
 Rotational speeds  
 Not recommended rotational speeds  
     for the pump MPS 10-1  
     for the pump MPS 10-2  
 Lubricants forced

10 (special executions 2...9)

6,3 MPa

0,16 cm<sup>3</sup>/cycle

acc. to the delivery chart

acc. to the delivery chart

maximum

minimum

plastic grease of the consistence class  $\leq 2$

acc. to PN-72/C-04095 (NLGI)

oils of  $\geq 30$  cSt/50°C viscosity

Ambient temperature	-10 ... 60°C
Power demand	0,18 kW
Rated voltage (drive S)	230/400 V or 500 V
Tank capacity	
pump MPS 10-1	2; 4,5; 6 dm <sup>3</sup>
pump MPS 10-2 (oil)	2 dm <sup>3</sup>
Weight	
pumps with drive A, B i C	10 kg
pumps with drive S	18 kg

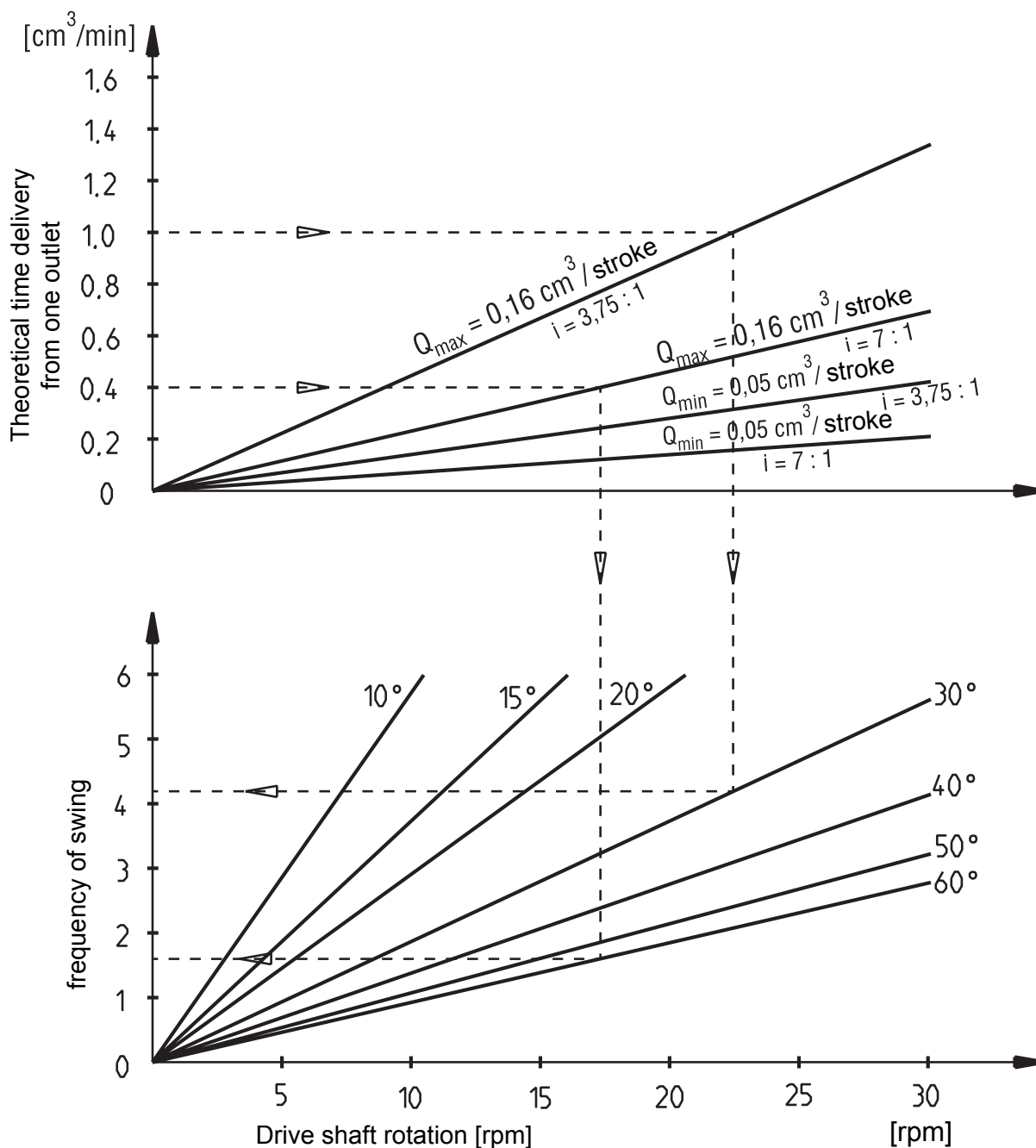

Fig. 1 Diagram of time delivery of pumps MPS 10-1 and MPS 10-2 type, with drive A

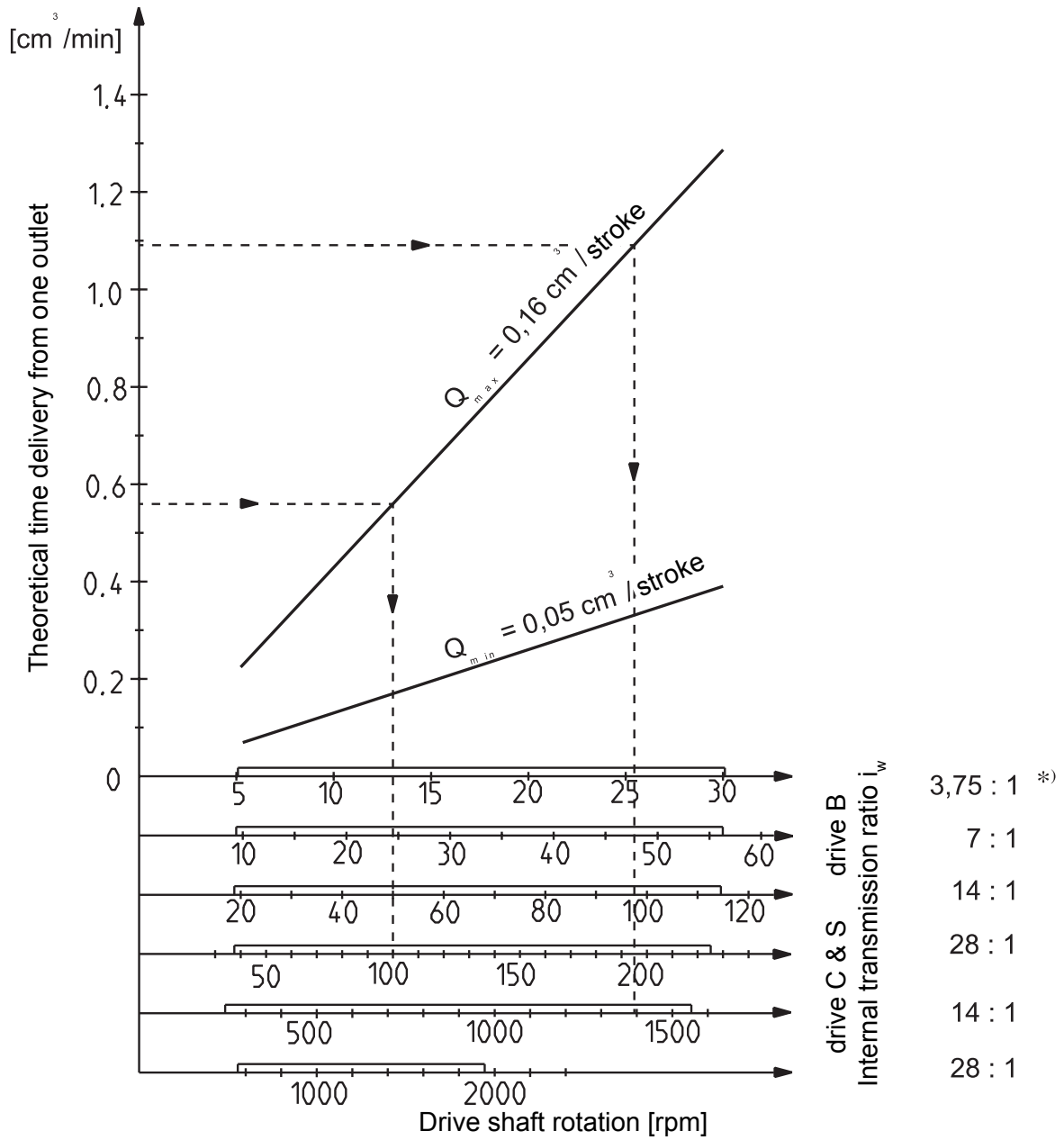

Fig. 2 Diagram of time delivery of pumps MPS 10-1 type, with drive B, C, S

\*) The values given apply to reduction of rotation

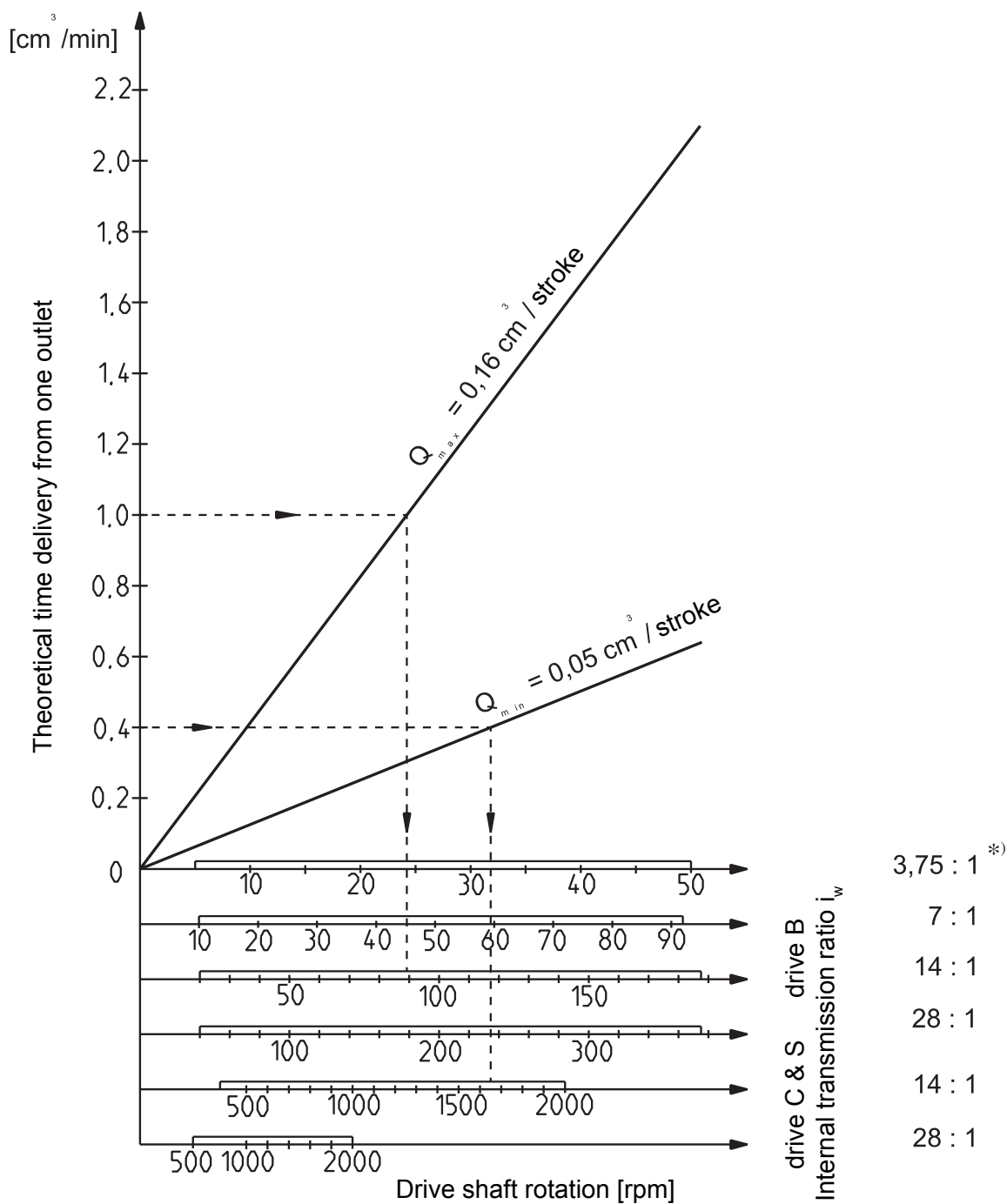
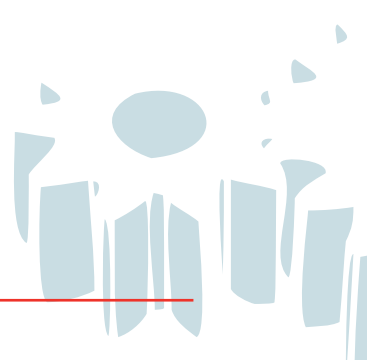

Fig. 3 Diagram of time delivery of pumps MPS 10-2 type, with drive B, C, S

\*) The values given apply to reduction of rotation





## Execution

Lubrication pump MPS 10 is made in variations which differ in:

- type of drive
  - oscillating drive - A
  - rotary drive - B
  - rotary drive with additional reduction gear (14:1) - C
  - drive for electric motor – S
  
- side of the drive installation
  - left - L
  - right - P
  
- position of driving shaft
  - level –a
  - upright - b
  
- direction of drive shaft rotation
  - right - 1
  - left – 2
  
- reduction gear inside the pump \*)
  - reduction 3.75 : 1 – 3.75
  - reduction 7:1 - 7
  - reduction 14 : 1 – 14
  - reduction 28 : 1 – 28
  
- tank capacity
  - capacity 3 dm<sup>3</sup> - 3
  - capacity 4.5 dm<sup>3</sup> - 4
  - capacity 6 dm<sup>3</sup> - 6
  
- rated voltage
  - 230/400 V, 50 Hz - 1
  - 500 V, 50 Hz –2

\*) The values given apply to reduction of rotation

Pump execution	Type of drive	Side of the drive installation	Position of driving shaft	Direction of rotating	Internal position	Tank capacity dm <sup>3</sup>	Rated voltage
MPS 10-1	<b>A</b>	L, P	-	-	3,75; 7	3; 4,5; 6	-
	<b>B</b>	L, P	-	1, 2	3,75; 7 14; 28		-
	<b>C</b>	L, P	a, b	1, 2	14; 28		-
	<b>S</b>	-	-	-	14; 28		1,2
MPS 10-2	<b>A</b>	L, P	-	-	3,75; 7	2	-
	<b>B</b>	L, P	-	1, 2	3,75; 7 14; 28		-
	<b>C</b>	L, P	a, b	1, 2	14; 28		-
	<b>S</b>	-	-	-	14; 28		1,2

## Symbols

Symbols should include the data concerning the type of execution in the order specified in the table.

## Examples of symbols

1. Grease lubrication pump (MPS 10-1) with oscillatory drive (A) installed on the right-hand side of the pump (P), with internal reduction 1:71 and a tank of 4.5 dm<sup>3</sup> capacity (4),  
e.g.: **Lubrication pump MPS 10-1AP/7-4**
2. Grease lubrication pump (MPS 10-1) with additional reduction gear (C) installed on the left-hand side of the pump (L), upright driving shaft (b), left rotation (2), internal reduction 3.75 : 1 (3.75) and a tank of 6 dm<sup>3</sup> capacity (6),  
e.g.: **Lubrication pump MPS 10-1CLb2/3.75-6**
3. Oil lubrication pump (MPS 10-2) with rotary drive (B), installed on the left-hand side of the pump (L), right rotation (1) and internal reduction 28 : 1 (28),  
e.g.: **Lubrication pump MPS 10-2BL1/28**
4. Grease lubrication pump (MPS 10-1), powered with an engine (S) of internal reduction 14:1 (14) and a tank of 6 capacity dm<sup>3</sup> (6) and an engine of 230/400 V rated voltage (1),  
e.g.: **Lubrication pump MPS 10-1S/14-6-1**

## Placing orders

The order should specify the name, type and execution of the pump, according to the symbols indicated above.

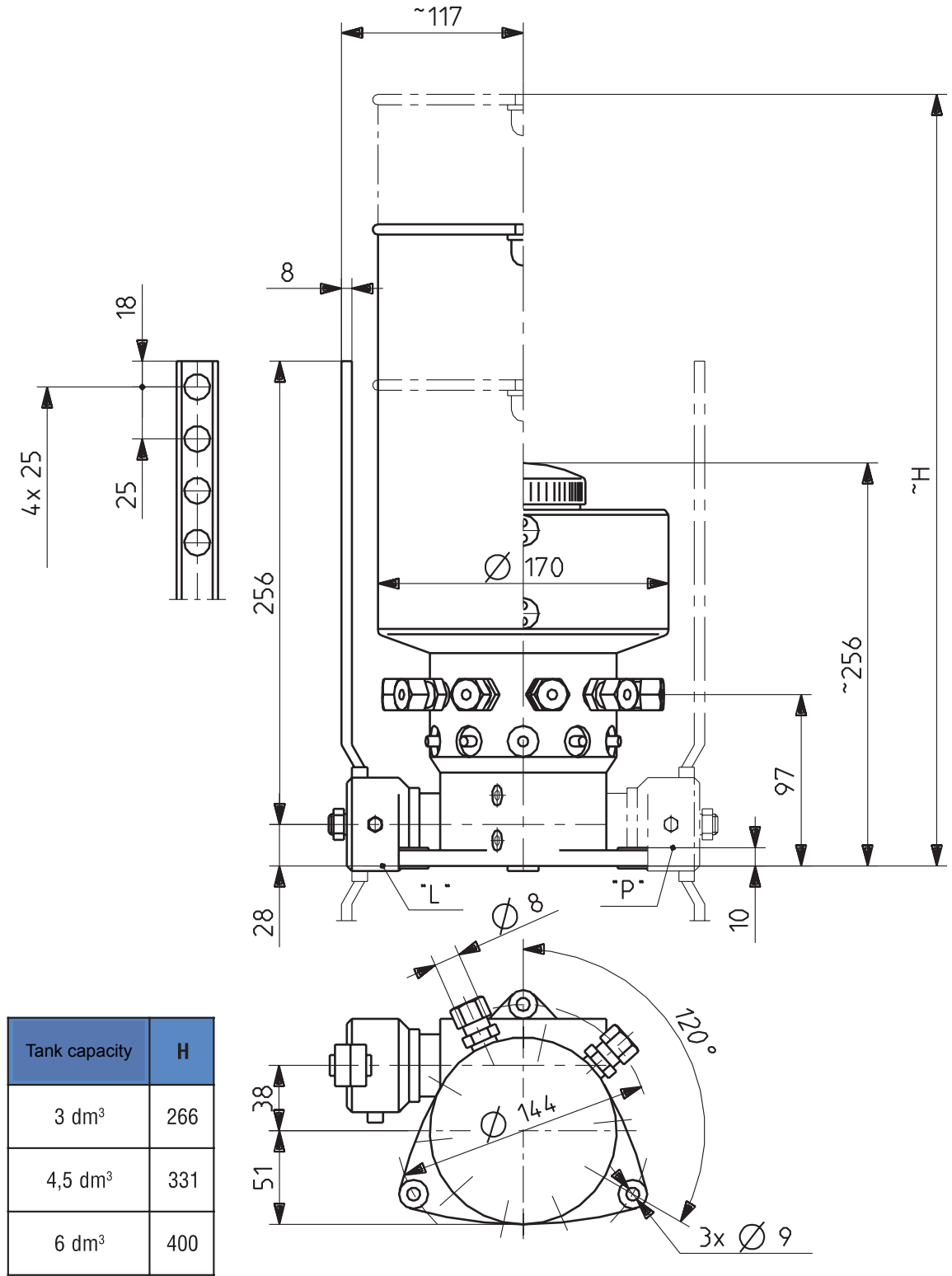

Fig. 4 Grease and oil lubrication pump with oscillatory drive of MPS 10-A type



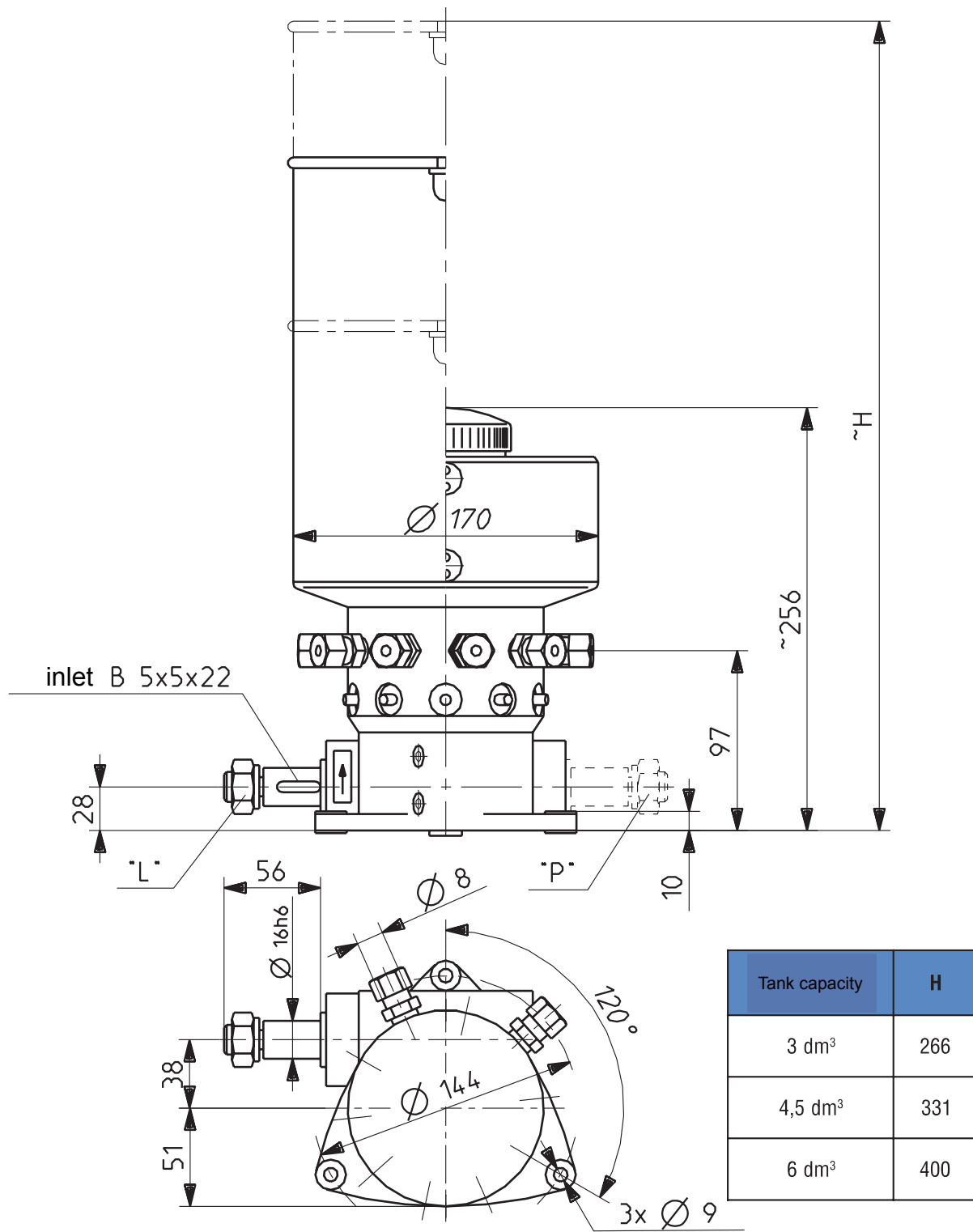
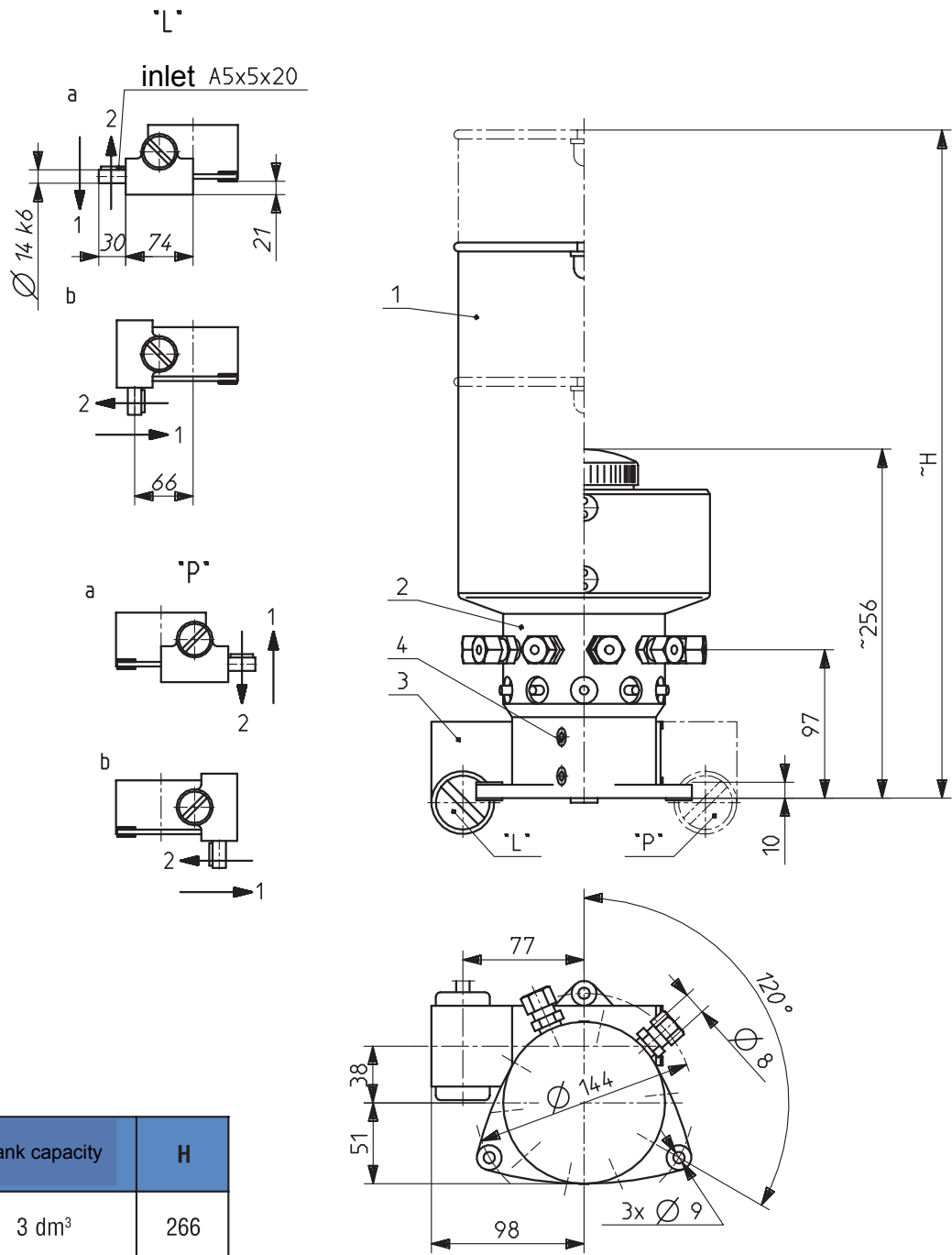
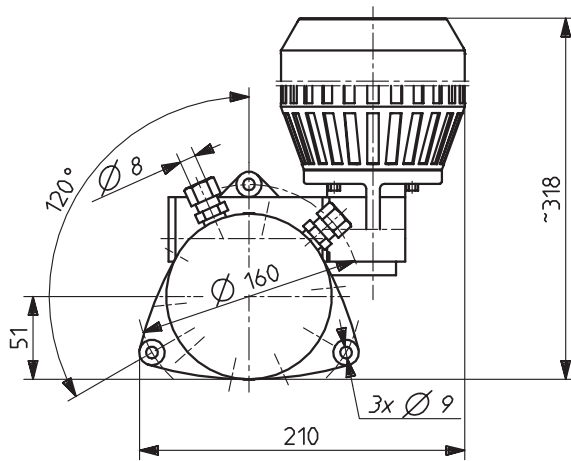
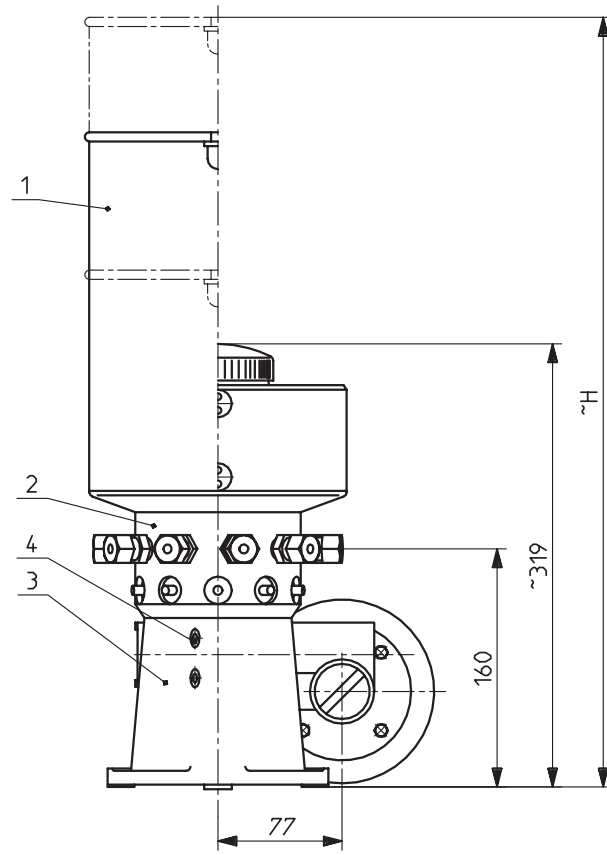

Fig. 5 Grease and oil lubrication pump with rotary drive of MPS 10-B type



Tank capacity	H
3 dm <sup>3</sup>	266
4,5 dm <sup>3</sup>	331
6 dm <sup>3</sup>	400

Fig. 6 Grease and oil lubrication pump with drive and additional reduction gear of MPS 10-C type



Tank capacity	H
3 dm <sup>3</sup>	266
4,5 dm <sup>3</sup>	331
6 dm <sup>3</sup>	400

Fig. 7 Grease and oil lubrication pump with drive of MPS 10-S type