

## DIAPHRAGM MULTI-SPRING PNEUMATIC ACTUATORS TYPE P1/R1

### APPLICATION AREA

The multi-spring diaphragm pneumatic actuators of P1/R1 type are applied for control operation of control valves and other positioning elements in industrial automatic systems.

There are three design options of the actuators:

- direct action (air - ejects the stem)
  - reverse action (air - retracts the stem)
  - direct action, handwheel
  - reverse action, handwheel
- type P1,
  - type R1,
  - type P1B,
  - type R1B

### FEATURES

- completely reversible action, option to change spring range w/o extra parts,
- rigid structure of cast yoke,
- wide range of available forces,
- linear dependence of stem movement from control pressure, due to application of diaphragms with constant effective area,
- various spring ranges achieved by changing the number of springs and/or changing position of spacer elements,
- capability of the actuator to incorporate side-mounted handwheel, pneumatic or electro-pneumatic positioners, limit switches, air sets, three-way pneumatic solenoid valves, lockup valves, position transducers,
- high strength of diaphragms, springs and packings,
- low weights and small overall dimensions.



### TECHNICAL PARAMETERS

- input signal range: 20...100 kPa; 40...120 kPa; 60...140 kPa - 3 springs  
 40...200 kPa; 80...240 kPa; 120...280 kPa - 6 springs  
 180...380 kPa - 12 springs
- max. supply pressure: Doubled number of springs (TANDEM version) for the 1500T actuator  
 400 kPa (450 kPa for the range 180...380 kPa)
- working temperature: - 40...+80°C
- relative humidity: max. 98%

Diaphragm effective area	Stroke	Spring range
[cm <sup>2</sup> ]	[mm]	[kPa]
400	20	1...6
630	20; 38	1...7
1000	38; 50; 63	
1500	38; 50; 63; 80; 100	
1500T	50; 63; 80; 100	

## DIMENSIONS AND WEIGHTS

Actuator size	A	B	C		D	E	F	d
			P1; P1B	R1; R1B				
[mm]								
400	453	305	127	100	57,15	17,7	255	M12x1,25
630	548	375	127	107		84,15	22,5	280
1000	773	477	153	90	57,15	17,7	340	M12x1,25
					84,15; 95,25	22,5		M16x1,5 M20x1,5
1500	833	550	184	102	57,15	17,7	410	M12x1,25
					84,15; 95,25	22,5		M16x1,5 M20x1,5
1500T	1138	550			84,15; 95,25			M24x1,5

Actuator size	Weight	
	P1; R1	P1B; R1B
	[kg]	
400	20	28
630	40	50
1000	85	105
1500	120	150
1500T	225	255

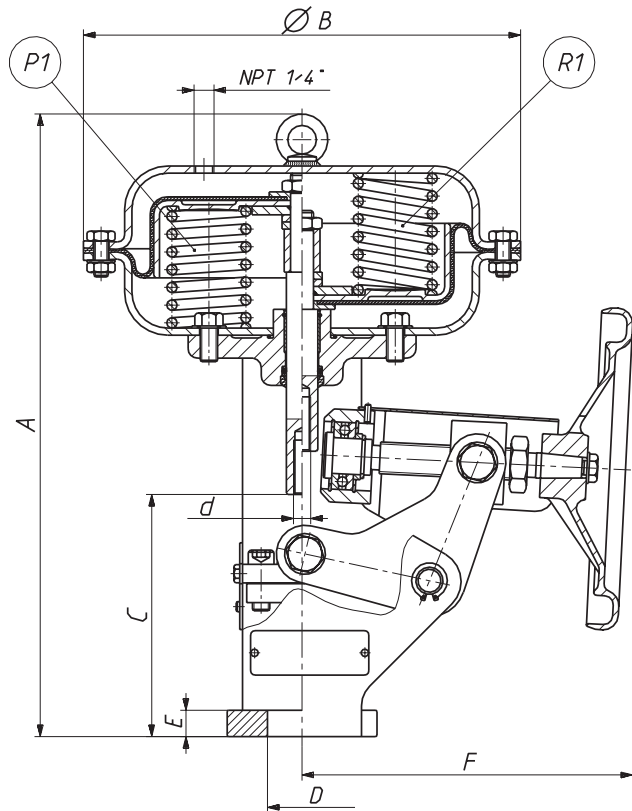

## PRODUCT CODE

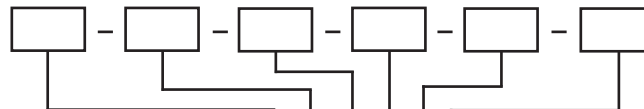

Type:	
- direct action:	<b>P1</b>
- reverse action:	<b>R1</b>
- direct action, with drive:	<b>P1B</b>
- reverse action, with drive:	<b>R1B</b>

Size:	
	<b>400</b>
	<b>630</b>
	<b>1000</b>
	<b>1500</b>
	<b>1500T</b>

Stroke [mm]:	
	<b>20</b>
	<b>38</b>
	<b>50</b>
	<b>63</b>
	<b>80</b>
	<b>100</b>

Connection thread:	
M12x1,25	<b>12</b>
M16x1,5	<b>16</b>
M20x1,5	<b>20</b>

Spud diameter [mm]:	
57,15	<b>57</b>
84,15	<b>84</b>
95,25	<b>95</b>

Spring range [kPa]:	
20...100	<b>1</b>
40...200	<b>2</b>
40...120	<b>3</b>
80...240	<b>4</b>
60...140	<b>5</b>
120...280	<b>6</b>
180...380	<b>7</b>

Example of the product code:

The pneumatic actuator of reverse action, with handwheel, size – 400, stroke 20 mm, spring range 40...200 kPa, with yoke  $\varnothing$  57,15, and connection thread M12x1,25:

**R1B - 400 - 20 - 2 - 57 - 12.**