

CENTRAL LUBRICATION PUMP PA 12 and PA 12G Type

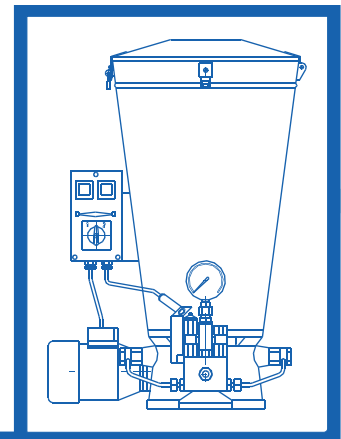

Central lubrication pump PD 12 & PA 12G

Central lubrication pump PD 12 & PA12G

Application

The pump is designed for lubricating friction nodes in vehicle chasses and machines. Lubricant is fed to the reception point equipped with a ball nipple by a lubrication gun joined to the pump by a flexible hose. The pump is recommended for equipping lubrication stands in vehicle and machine service stations. It may also be used to lubricate friction nodes in dredging excavators, dredgers and other equipment of strip mines, as well as in underground mine workings (e.g. in copper mines).

Construction

The pump consists of the following assemblies:

- a tank with a grease feeding device,
- a power transmission system comprising an electrical motor, single-stage worm gear put into a common body with an eccentric power transmission system,
- two forcing units of various capacity, comprising forcing elements in which pistons receive power from the eccentric power transmission system, return valves and pressure conduits,
- control valve comprising a control slide, two overflow valves (the left one equipped with a valve piston movement gauge), inductive contactless switch mating the piston movement gauge and pressure gauge,
- control device mating an inductive proximity sensor placed in the control valve,
- an electric device signalling the minimum and maximum level of lubricant in the tank (special accessory).

Operation

The pump is powered by an electric motor. The engine shaft rotation is transmitted through a worm gear to the eccentric power transmission system and grease feeding device. The feeding device drift fender separates the lubricant from the tank face, while the feeding screw of the device kneads it initially and passes to the sucking area of the forcing units. Pistons of the forcing units, with a reciprocating movement induced by the eccentric power transmission system, force the lubricant to the return valve. The left forcing unit forces 75 cm³/min and the right one 125 cm³/min.

The control valve is for directing the lubricant forced through the left and the right forcing unit to their joint outlet and maintaining the maximum pressure set with overflow valves for each forcing unit. Maximum pressure for the left unit may be set at 40 MPa, and for the right at 20 MPa. The pressure gauge installed on the control valve indicates momentary pressure induced by the forcing units.

The pump is designed to operate with two types of control: hydraulic and electro-hydraulic. The type of control is selected with a cam connector placed on the control device. If the connector is in position „1”, only hydraulic control works. In this case, the pump operates continuously and the lubricant is forced according to the dependences shown in the diagram (Fig. 1).

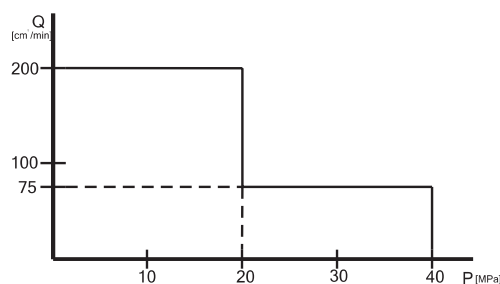
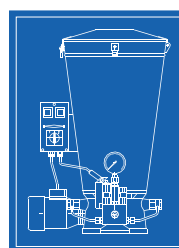

Fig. 1

If the connector is in position “2”, the electro-hydraulic control system works. The pump forces lubricant until the maximum set pressure is achieved; then, the inductive proximity sensor activates and transmits a signal to the control device which stops the engine. The pump starts again when the pressure drops (e.g. if the lubrication gun opens) to the preset minimum value. The pressure boundary values at which the pump starts or stops are preset with the overflow valve with an adjusting nut of the valve piston movement gauge.

Because of stroke adjustment of the pump delivery it is possible to fill the lubricant reception point quickly at low pressure and force it at high pressure. This feature is also useful if there is a need to remove solids, which occur with the lubricant ageing or soiling, from the lubrication area (at high pressure and low delivery). When the line is unobstructed, further filling takes place at lower pressure and full pump delivery.

Technical details



Delivery

- at pressure up to 20 MPa
- at pressure 20...40 MPa

Maximum pressure

- for the right forcing unit
- for the left forcing unit

200 cm³/min

75 cm³/min

20 MPa

40 MPa

Pressure range during automatic operation

18...28 MPa

Power demand

0,75 kW

Rated voltage

230/400 V or 500 V, 50 Hz

Lubricants forced

plastic grease of the consistence class ≤ 2 acc. to PN-72/C-0490 (NLGI)

Ambient temperature

-10...60°C

Tank capacity

63 dm³

Weight

65 kg

Pipe coupling

Straight coupling 320-10

acc. to PN-65/M-73126

Power lead choke

Db 11

Execution

The pump is manufactured in variations which differ in rated value and the use or not of the lubricant level in the tank gauge. Pump symbols are indicated in the table:

Pump symbol	Rated voltages	Level gauge used / not used	Execution
PA12-1	230 / 400 V	NO	Standard execution (Fig. 2)
PA12-2	500 V		
PA12-3	230 / 400 V	YES	
PA12-4	500 V		
PA12G-2	500 V	NO	Execution for applying to underground mine workings with no threat of explosion (Rys. 3)
PA12G-4		YES	

Note: Lubrication gun and flexible hose are not attached.

Placing orders

The order should specify the name and symbol of the pump.

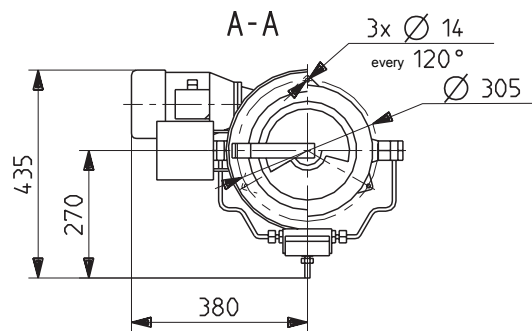
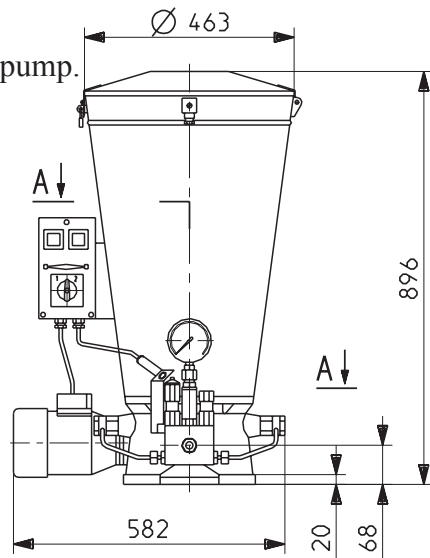

Fig. 2 Overall and linkage dimensions of the pump PA 12

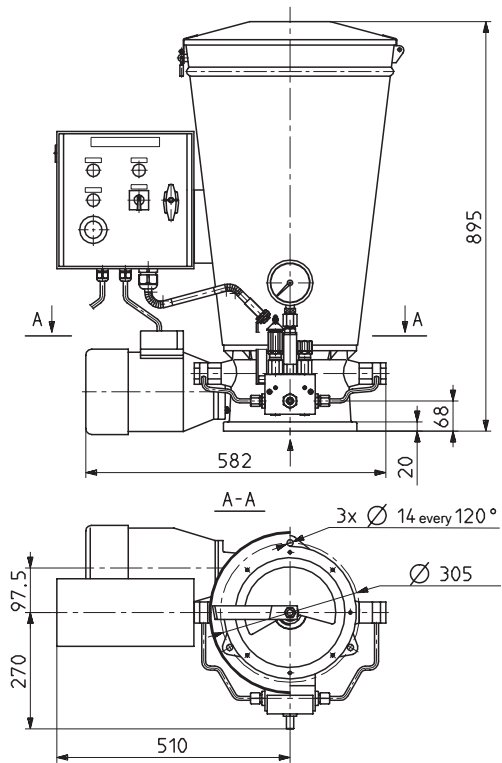

Fig. 3 Overall and linkage dimensions of the pump PA 12G

Manufacturer and Distributor
 Zakłady Automatyki „Polna” S.A.
 37-700 Przemyśl, 23 Obozowa St.
 telephone: +48 16-678-66-01
 fax.: +48 16-678-65-24, +48 16-678-37-10
 www.polna.com.pl
 e-mail: marketing@polna.com.pl